

TYPICAL BBA COURSE SELECTION ORDER

SUPPLY CHAIN MANAGEMENT MAJOR

This information is provided to act as a guide for your course selection throughout your degree, and takes into account course levelling and prerequisites. Your order of courses is ultimately determined by prerequisites and course scheduling, and you don't have to follow this exact timeline.

YEAR 1 (Common for ALL majors)

- | | |
|--|---|
| <input type="checkbox"/> ACCT 2121 - Financial Accounting Concepts | <input type="checkbox"/> HRES 2170 - Introduction to Human Resources |
| <input type="checkbox"/> ECON 1101 - Principles of Microeconomics | <input type="checkbox"/> MGMT 2262 - Business Statistics I |
| <input type="checkbox"/> ECON 1103 - Principles of Macroeconomics | <input type="checkbox"/> MKTG 2150 - Introduction to Marketing |
| <input type="checkbox"/> Business Option - take one (1) of: ENTR 2301 - Innovation and the Entrepreneurial Practice, MGMT 2130 - Management Principles and Practices, or SINV 2201 - Introduction to Social Innovation _____ | <input type="checkbox"/> GNE1 11XX - Foundation Cluster 1 _____ |
| | <input type="checkbox"/> GNE1 14XX - Foundation Cluster 4 _____ |
| | <input type="checkbox"/> One (1) of: GNE1 12XX - Foundation Cluster 2 or GNE1 13XX - Foundation Cluster 3 _____ |

To declare a major in Supply Chain Management, please email Student Records at studentrecords@mtroyal.ca.

YEAR 2

CORE REQUIREMENTS

- ACCT 3224 - Management Accounting I
- FNCE 3227 - Introduction to Finance
- LSCM 3403 - Operations Management
- MGMT 3230 - Business Law

GENERAL EDUCATION REQUIREMENTS

- Remaining Foundation GNE1 course _____
- GNE1 Tier 2, Cluster 1 _____

MAJOR REQUIREMENTS

- LSCM 2201 - Introduction to Logistics & Supply Chain Management
- LSCM 2301 - Introduction to Physical Distribution
- LSCM 3303 - Foundations of Purchasing

(F) = Fall semester only (W) = Winter semester only

ELECTIVES

- Elective #1 _____

YEAR 3

CORE REQUIREMENTS

- INBU 3301 - Global Business Environment
- MGMT 3210 - Business Communication Theory & Practice
- MGMT 3276 - Organizational Behaviour

GENERAL EDUCATION REQUIREMENTS

- GNE1 Tier 2 } _____
 - GNE1 Tier 2 } _____
- Must select from two of Clusters 2, 3 or 4

MAJOR REQUIREMENTS

- LSCM 3203 - Principles of Quality Management
- LSCM 3305 - Physical Distribution and Logistics
- MGMT 4230 - Advanced Business Law
- LSCM 3407 - Business Negotiations/Project Management OR MGMT 3269 - Project Management

ELECTIVES

- Elective #2 _____

YEAR 4

CORE REQUIREMENTS

- ENTR 4433 - Business Plan Development
- MGMT 5333 - Strategic Management

GENERAL EDUCATION REQUIREMENTS

- GNE1 Tier 3 } _____
 - GNE1 Tier 3 } _____
 - GNE1 Tier 3 } _____
- Must select from a minimum of 2 Clusters

MAJOR REQUIREMENTS

- LSCM 3402 - Inventory & Warehouse Management
- LSCM 4409 - Supply Chain Decision Making (W)
- LSCM 4411 - Integrated Business Solutions (W)

ELECTIVES

- Elective #3 _____
- Elective #4 _____

Please note: Many courses have prerequisites. All students are responsible to ensure that they have the appropriate prerequisites before enrolling in their courses. Please refer to the Mount Royal University Calendar for prerequisite listings. Every effort is made to ensure this document is up-to-date, but in the event of a discrepancy between this degree checklist and the academic calendar, the academic calendar is deemed correct.

Planning your Supply Chain Management Major coursework

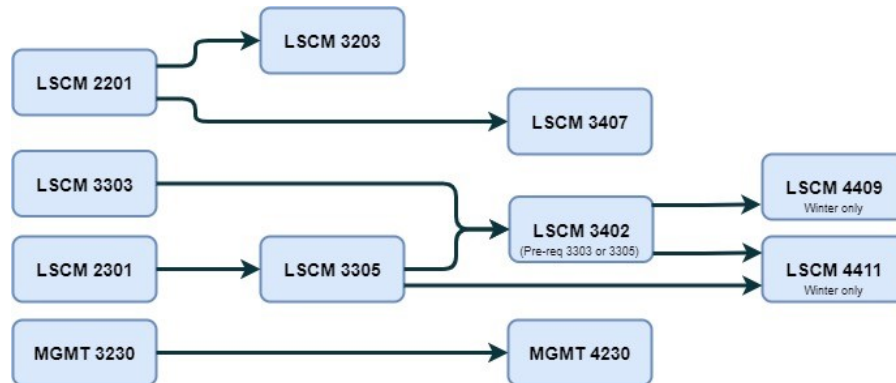

The chart above illustrates the courses required to complete the major in Supply Chain Management taking into consideration course prerequisites.

BBA Terminology

The BBA is made up of:

- **16 core** courses (that all BBA students must take)
- **10 major** courses (dependent on the major/concentration you choose)
- **10 General Education** courses (the breadth of your degree)
- **4 elective** courses (courses of your choice, but could include BBA minor or Honours coursework, exploratory coursework to help you choose your major, further coursework in your intended field, international exchange courses, and field school opportunities)

What are...

Pre-requisites - courses that must successfully be completed *PRIOR* to taking a higher-level course (i.e. ACCT 2121 is a pre-requisite for ACCT 3224).

Co-requisites - courses that can be taken concurrently with other coursework (i.e. LSCM 3403 is a pre or co-requisite for MGMT 5333).

Recommended preparation - where having prior coursework in the subject may prove beneficial to students, but is not required for high-level courses.

Advice from your Advisors

- Consider a balanced approach when picking your courses
 - * Take core, major, general education and elective courses each semester.
 - * Consider your personal strengths and weaknesses when picking courses to achieve a reasonable course load and workload.
 - * Keep in mind your commitments outside of the classroom (work, student clubs, volunteering, etc.) when determining your schedule of courses.
- Communicate any difficulties that you are having with your professor - the earlier you identify any issues, the earlier you can address them!
- If you aren't sure what to major in, use your electives to explore areas of interest - the earlier you do this, the earlier you can declare your major and plan the rest of your degree.
- The majority of core BBA courses are offered in the Fall, Winter and Spring semesters - but major specific courses may only be offered once per year or only in the Fall and Winter. Consult with your Advisor if you have questions.

Outside the Classroom - Things to Consider

FIRST YEAR



Courses include common first-year introductory business courses and General Education courses

- Explore major/minor/concentration options
- Apply for Co-operative Education
- Attend Career Services workshops
- Attend Student Learning Services workshops
- Take advantage of a free MRU Recreation membership
- Attend Majors/Minors Fair

SECOND YEAR



Coursework expands on foundation business courses and introduces students to specific areas of specialization in the BBA.

- Declare a major/minor/concentration
- Explore BBA Honours program
- Join Bissett and SAMRU clubs
- Meet with your Academic Advisor
- Use mruGradU8 to stay on track
- Sign up for the Student Job Board to secure relevant summer work experience
- Visit the Slate Innovation Lab and the Trico Changemakers Studio

THIRD YEAR



Courses focus on specific major/minor/concentration requirements and electives

- Explore volunteer opportunities
- Go to workshops, panel discussions and conferences
- Explore mentorship opportunities
- Explore international exchange, field school and summer exchange opportunities
- Apply for BBA Honours program
- Check in with your Academic Advisor to make sure you're on track

FOURTH YEAR



Courses include capstone business and major specific requirements, requiring students to apply the knowledge they've gained at MRU.

- Apply to graduate
- Explore graduate degree and post-graduate opportunities
- Research options for post-graduate designations and continuing education
- Request a critique of your resume with Career Services via email
- Consider various research opportunities, including taking a directed readings course