

TYPICAL BBA COURSE SELECTION ORDER

GENERAL MANAGEMENT MAJOR/FINANCIAL SERVICES CONCENTRATION

This information is provided to act as a guide for your course selection throughout your degree, and takes into account course levelling and prerequisites. Your order of courses is ultimately determined by prerequisites and course scheduling, and you don't have to follow this exact timeline.

YEAR 1 (Common for ALL majors)

- ACCT 2121 - Financial Accounting Concepts
- ECON 1101 - Principles of Microeconomics
- ECON 1103 - Principles of Macroeconomics
- One (1) of: ENTR 2301 - Innovation and the Entrepreneurial Practice, MGMT 2130 - Management Principles and Practices, or SINV 2201 - Introduction to Social Innovation
- HRES 2170 - Introduction to Human Resources
- MGMT 2262 - Business Statistics I
- MKTG 2150 - Introduction to Marketing
- GNED 11XX - Foundation Cluster 1
- GNED 14XX - Foundation Cluster 4
- One (1) of: GNED 12XX - Foundation Cluster 2 or GNED 13XX - Foundation Cluster 3

YEARS 2 and 3

CORE REQUIREMENTS

- ACCT 3224 - Management Accounting I
- INBU 3301 - Global Business Environment
- MGMT 3210 - Business Communication Theory & Practice
- MGMT 3230 - Business Law
- FNCE 3227 - Introduction to Finance
- LSCM 3403 - Operations Management
- MGMT 3276 - Organizational Behaviour

GENERAL EDUCATION REQUIREMENTS

- Remaining Foundation GNED course
- GNED Tier 2, Cluster 1
- GNED Tier 2 } Must select from two of Clusters 2, 3 or 4
- GNED Tier 2 }

CONCENTRATION REQUIREMENTS

- FNCE 3201 - Retirement Planning (F)
- FNCE 3203 - Income Tax Planning (W)
- FNCE 3205 - Strategic Investment Planning (W)
- FNCE 3207 - Risk Management & Estate Planning (F)
- FNCE 3228 - Advanced Corporate Finance
- FNCE 3302 - International Finance

(F) = Fall semester (W) = Winter semester

ELECTIVES

- Elective #1
- Elective #2
- Elective #3

YEAR 4

CORE REQUIREMENTS

- ENTR 4433 - Business Plan Development
- MGMT 5333 - Strategic Management

GENERAL EDUCATION REQUIREMENTS

- GNED Tier 3 } Must select from a
- GNED Tier 3 } minimum of two Clusters
- GNED Tier 3 }

CONCENTRATION REQUIREMENTS

- FNCE 4407 - Investments & Portfolio Management
- FNCE 5010 - Advanced Topics in Finance (W)
- FNSR Option #1*
- FNSR Option #2*

ELECTIVES

- Elective #4

*List of approved FNSR Options on reverse

Please note: Many courses have prerequisites. All students are responsible to ensure that they have the appropriate prerequisites before enrolling in their courses. Please refer to the Mount Royal University Calendar for prerequisite listings. Every effort is made to ensure this document is up-to-date, but in the event of a discrepancy between this degree checklist and the academic calendar, the academic calendar is deemed correct.

Planning your Financial Services Concentration coursework

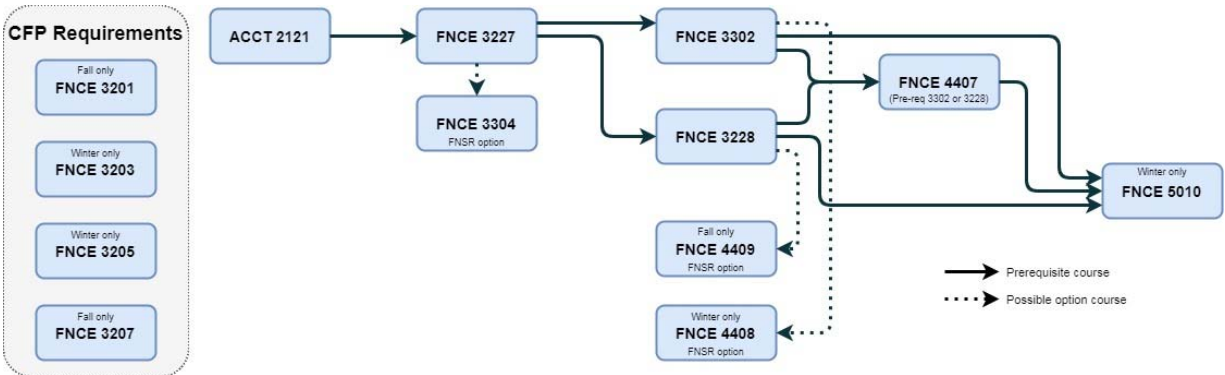

The chart above illustrates the courses required to complete the concentration in Financial Services, taking into consideration course prerequisites. Required FNSR Options include any four of: FNCE 3304, FNCE 3399/4499, FNCE 4408, FNCE 4409, MKTG 3150

BBA Terminology

The BBA is made up of:

- 16 core courses (that all BBA students must take)
- 10 major courses (dependent on the major/concentration you choose)
- 10 General Education courses (the breadth of your degree)
- 4 elective courses (courses of your choice, but could include BBA minor or Honours coursework, exploratory coursework to help you choose your major, further coursework in your intended field, international exchange courses, and field trip opportunities)

What are...

Pre-requisites - courses that must successfully be completed *PRIOR* to taking a higher-level course (i.e. ACCT 2121 is a pre-requisite for ACCT 3224).

Co-requisites - courses that can be taken concurrently with other coursework (i.e. LSCM 3403 is a pre or co-requisite for MGMT 5333).

Recommended preparation - where having prior coursework in the subject may prove beneficial to students, but is not required for higher-level courses.

Advice from your Advisors

- Consider a balanced approach when picking your courses
 - * Take core, major, general education and elective courses each semester.
 - * Consider your personal strengths and weaknesses when picking courses to achieve a reasonable courseload and workload.
 - * Keep in mind your commitments outside of the classroom (work, student clubs, volunteering, etc.) when determining your schedule of courses.
- Communicate any difficulties that you are having with your professor - the earlier you identify any issues, the earlier you can address them!
- If you aren't sure what to major in, use your electives to explore areas of interest - the earlier you do this, the earlier you can declare your major and plan the rest of your degree.
- The majority of core BBA courses are offered in the Fall, Winter and Spring semesters - but major specific courses may only be offered once per year or only in the Fall and Winter. Consult with your Advisor if you have questions.

Outside the Classroom - Things to Consider

<h3>YEAR 1</h3>	<ul style="list-style-type: none"> • Explore major/concentration/minor options • Apply for Co-operative Education • Attend Career Services and Student Learning Services workshops • Use mruGradU8 to stay on track • Attend Majors/Minors Fair 	<h3>THROUGHOUT YOUR DEGREE</h3> <ul style="list-style-type: none"> • Join Bissett clubs • Volunteer • Go to workshops, panel discussions and conferences • Meet with your Academic Advisor • Join Recreation • Explore SAMRU
<h3>YEARS 2 and 3</h3>	<ul style="list-style-type: none"> • Declare a major/concentration/minor • Explore the BBA Honours degree • Attend Career Services and Student Learning Services workshops • Explore Co-operative Education and International exchange opportunities • Explore volunteer possibilities and check out on and off-campus events 	
<h3>YEAR 4</h3>	<ul style="list-style-type: none"> • Apply to graduate • Attend Career Services workshops and Career Fair • Explore graduate degree and post-graduate opportunities, including the CFP • Join groups on LinkedIn, and consider joining professional associations • Make plans for life after MRU 	